

FEATURES

- 10-bit ADC with 15 μ s and 30 μ s conversion times
- Single and 4 single-ended analog input channels
- On-chip temperature sensor: -40°C to $+125^{\circ}\text{C}$
- On-chip track-and-hold
- Overtemperature indicator
- Automatic power-down at the end of a conversion
- Wide operating supply range: 2.7 V to 5.5 V
- I²C-compatible serial interface
- Selectable serial bus address allows connection of up to 8 AD7416/AD7417 devices to a single bus
- AD7416 is a superior replacement for LM75

APPLICATIONS

- Data acquisition with ambient temperature monitoring
- Industrial process control
- Automotive
- Battery-charging applications
- Personal computers

GENERAL DESCRIPTION

The AD7417 and AD7418 are 10-bit, 4-channel and single-channel ADCs with an on-chip temperature sensor that can operate from a single 2.7 V to 5.5 V power supply. The devices contain a 15 μ s successive approximation converter, a 5-channel multiplexer, a temperature sensor, a clock oscillator, a track-and-hold, and a reference (2.5 V). The AD7416 is a temperature-monitoring only device in an 8-lead package.

The temperature sensor on the parts can be accessed via multiplexer Channel 0. When Channel 0 is selected and a conversion is initiated, the resulting ADC code at the end of the conversion gives a measurement of the ambient temperature ($\pm 1^{\circ}\text{C}$ at 25°C). On-chip registers can be programmed with high and low temperature limits, and an open-drain overtemperature indicator (OTI) output is provided, which becomes active when a programmed limit is exceeded.

A configuration register allows programming of the sense of the OTI output (active high or active low) and its operating mode (comparator or interrupt). A programmable fault queue counter allows the number of out-of-limit measurements that must occur before triggering the OTI output to be set to prevent spurious triggering of the OTI output in noisy environments.

FUNCTIONAL BLOCK DIAGRAMS

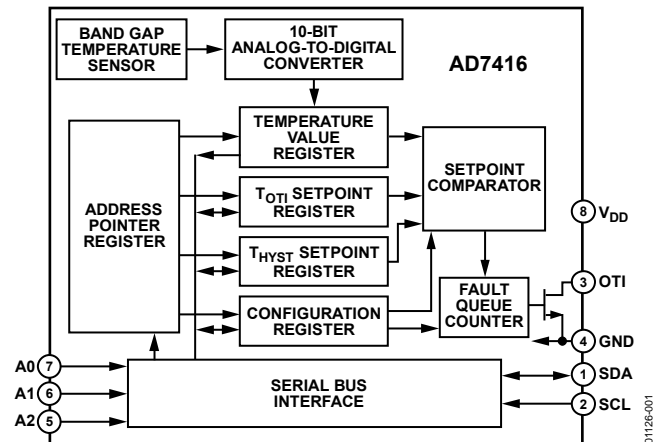

Figure 1. AD7416

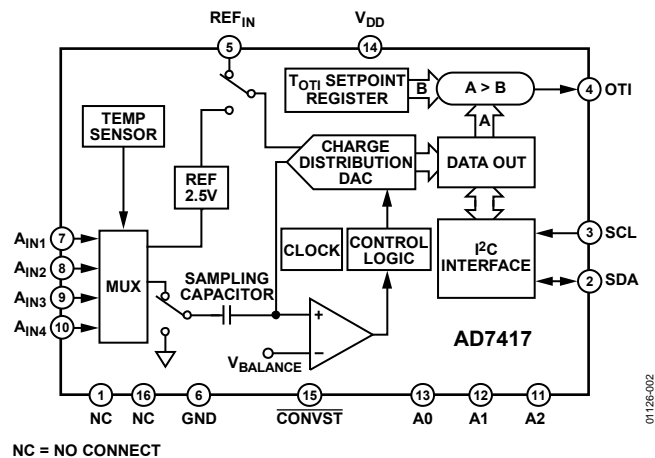

Figure 2. AD7417

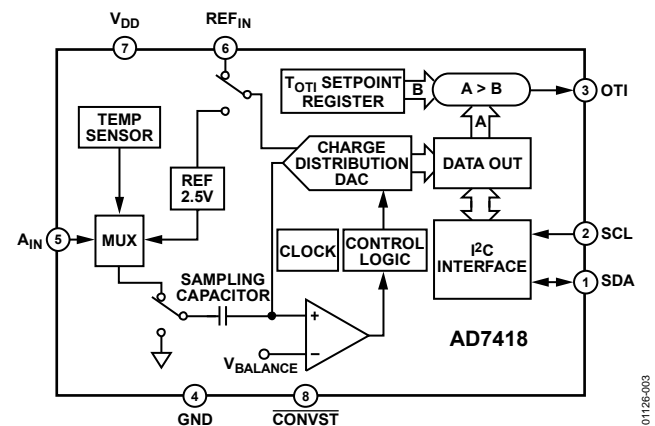

Figure 3. AD7418

Rev. J

[Document Feedback](#)

Information furnished by Analog Devices is believed to be accurate and reliable. However, no responsibility is assumed by Analog Devices for its use, nor for any infringements of patents or other rights of third parties that may result from its use. Specifications subject to change without notice. No license is granted by implication or otherwise under any patent or patent rights of Analog Devices. Trademarks and registered trademarks are the property of their respective owners.

TABLE OF CONTENTS

Features	1	On-Chip Reference	11
Applications.....	1	Temperature Measurement.....	12
General Description	1	Internal Register Structure.....	12
Functional Block Diagrams.....	1	Serial Bus Interface.....	14
Revision History	2	OTI Output	17
Product Highlights	3	Fault Queue.....	17
Specifications.....	4	Power-On Defaults.....	17
AD7417/AD7418 Specifications.....	4	Operating Modes.....	17
AD7416 Specifications.....	6	CONVST Start Mode.....	18
Absolute Maximum Ratings.....	7	Applications Information	19
ESD Caution.....	7	Supply Decoupling	19
Pin Configurations and Function Descriptions	8	Power-On Reset.....	19
Terminology	10	Mounting the AD7416/AD7417/AD7418	19
Theory of Operation	11	Fan Controller.....	19
Circuit Information.....	11	Thermostat.....	19
Converter Details.....	11	System with Multiple AD7416 Devices.....	20
Typical Connection Diagram.....	11	Outline Dimensions	21
Analog Inputs.....	11	Ordering Guide	22
REVISION HISTORY		Updated Outline Dimensions.....	21
4/2018—Rev. I to Rev. J		Changes to Ordering Guide.....	23
Changes to Product Title.....	1	8/2004—Rev. F to Rev. G	
Changes to Ordering Guide.....	22	Changes to Figure 12.....	12
11/2010—Rev. H to Rev. I		Changes to Reading Data from the AD7416/AD7417/AD7418 Section.....	13
Changes to Figure 19.....	16	Changes to Power-On-Reset section	14
2/2009—Rev. G to Rev. H		7/2003—Rev. E to Rev. F	
Updated Format.....	Universal	Changes to Features Section	1
Changes to Data Sheet Title, Figure 2 and Figure 3.....	1	Changes to Specifications Section.....	3
Moved Product Highlights Section.....	3	Changes to Absolute Maximum Ratings Section.....	6
Changes to Table 1.....	4	Changes to Ordering Guide Section	6
Changes to Endnote 1, Table 2.....	6	Changes to Product Highlights Section	7
Added Figure 5 Caption.....	7	Changes to Circuit Information Section	7
Changes to Table 4.....	8	Changes to Temperature Measurement Section.....	9
Changes to Table 5 and Table 6.....	9	10/2002—Rev. D to Rev. E	
Changes to On-Chip Reference Section.....	11	Changes to Specifications Headings	2
Changes to Figure 13.....	12	Added Temperature Measurement Section	8
Changes to Table 8 and Table 10.....	13	Changes to Serial Bus Address Section	10
Changes to Figure 15, Figure 16, and Figure 17	15	Changes to Figure 11.....	12
Changes to Reading Data from the AD7416/AD7417/AD7418 Section, Figure 18, and Figure 19	16	Changes to CONVST Pin Mode Section.....	14
Change to Mode 1	17	Changes to Power-On-Reset Section.....	14
Changes to Figure 22 Caption and $\overline{\text{CONVST}}$ Pin Mode Section.....	18	Inserted Figure 16 and Figure 17; Renumbered Sequentially ..	15
Moved Figure 21 and Figure 22	18	Updated Outline Dimensions.....	16
Changes to Power-On Reset Section.....	19		

An I²C[®] compatible serial interface allows the AD7416/AD7417/AD7418 registers to be written to and read back. The three LSBs of the AD7416/AD7417 serial bus address can be selected, which allows up to eight AD7416/AD7417 devices to be connected to a single bus.

The AD7417 is available in a narrow body, 0.15 inch, 16-lead, small outline package (SOIC) and in a 16-lead, thin shrink, small outline package (TSSOP). The AD7416 and AD7418 are available in 8-lead SOIC and MSOP packages.

PRODUCT HIGHLIGHTS

1. The AD7416/AD7417/AD7418 have an on-chip temperature sensor that allows an accurate measurement of the ambient temperature ($\pm 1^{\circ}\text{C}$ at 25°C , $\pm 2^{\circ}\text{C}$ overtemperature) to be made. The measurable temperature range is -40°C to $+125^{\circ}\text{C}$. An overtemperature indicator is implemented by carrying out a digital comparison of the ADC code for Channel 0 (temperature sensor) with the contents of the on-chip T_{OTI} setpoint register.
2. The AD7417 offers a space-saving, 10-bit analog-to-digital solution with four external voltage input channels, an on-chip temperature sensor, an on-chip reference, and a clock oscillator.
3. The automatic power-down feature enables the AD7416/AD7417/AD7418 to achieve superior power performance. At slower throughput rates, the part can be programmed to operate in a low power shutdown mode, allowing further savings in power consumption.

SPECIFICATIONS

AD7417/AD7418 SPECIFICATIONS

$V_{DD} = 2.7 \text{ V}$ to 5.5 V , $GND = 0 \text{ V}$, $REF_{IN} = 2.5 \text{ V}$, unless otherwise noted.

Table 1.

Parameter	A Version	B Version ¹	Unit	Test Conditions/Comments
DC ACCURACY				Any channel
Resolution	10	10	Bits	
Minimum Resolution for Which No Missing Codes Are Guaranteed	10	10	Bits	
Relative Accuracy ²	±1	±1	LSB max	This specification is typical for V_{DD} of 3.6 V to 5.5 V
Differential Nonlinearity ²	±1	±1	LSB max	This specification is typical for V_{DD} of 3.6 V to 5.5 V
Gain Error ²	±3	±3	LSB max	External reference
	±10	±10	LSB max	Internal reference
Gain Error Match ²	±0.6	±0.6	LSB max	AD7417 only
Offset Error ²	±4	±4	LSB max	
Offset Error Match ²	±0.7	±0.7	LSB max	AD7417 only
ANALOG INPUTS				
Input Voltage Range	VREF	VREF	V max V min	
Input Leakage Current ³	±1	±1	µA max	
Input Capacitance	10	10	pF max	
TEMPERATURE SENSOR ¹				
Measurement Error				
Ambient Temperature 25°C	±2	±1	°C max	
T_{MIN} to T_{MAX}	±3	±2	°C max	
Temperature Resolution	1/4	1/4	°C/LSB	
CONVERSION RATE				
Track-and-Hold Acquisition Time ⁴	400	400	ns max	Source impedance < 10 Ω
Conversion Time				
Temperature Sensor	30	30	µs max	Typically 27 µs
Channel 1 to Channel 4	15	15	µs max	Typically 10 µs
REFERENCE INPUT ^{5,6}				
REF _{IN} Input Voltage Range	2.625 2.375	2.625 2.375	V max V min	2.5 V + 5% 2.5 V – 5%
Input Impedance	40	40	kΩ min	
Input Capacitance	10	10	pF max	
ON-CHIP REFERENCE				Nominal 2.5 V
Reference Error ⁶	±25	±25	mV max	
Temperature Coefficient ⁶	80	80	ppm/°C typ	
DIGITAL INPUTS				
Input High Voltage, V_{IH}	$V_{DD} \times 0.7$	$V_{DD} \times 0.7$	V min	
Input Low Voltage, V_{IL}	$V_{DD} \times 0.3$	$V_{DD} \times 0.3$	V max	
Input Leakage Current	1	1	µA max	
DIGITAL OUTPUTS				
Output Low Voltage, V_{OL}	0.4	0.4	V max	$I_{OL} = 3 \text{ mA}$
Output High Current	1	1	µA max	$V_{OH} = 5 \text{ V}$

Parameter	A Version	B Version ¹	Unit	Test Conditions/Comments
POWER REQUIREMENTS				
V _{DD}	5.5 2.7	5.5 2.7	V max V min	For specified performance
I _{DD}				Logic inputs = 0 V or V _{DD}
Normal Operation	600	600	μA max	
Power-Down	1.5	1.5	μA max	0.7 μA typically
Auto Power-Down Mode				V _{DD} = 3 V; see the Operating Modes section
10 SPS Throughput Rate	6	6	μW typ	
1 kSPS Throughput Rate	60	60	μW typ	
10 kSPS Throughput Rate	600	600	μW typ	
Power-Down	3	3	μW max	Typically 0.15 μW

¹ B Version applies to AD7417 only with temperature range of -40°C to +85°C. A Version temperature range is -40°C to +125°C. For V_{DD} = 2.7 V, T_A = 85°C maximum and temperature sensor measurement error = ±3°C maximum.

² See the Terminology section.

³ Refers to the input current when the part is not converting. Primarily due to reverse leakage current in the ESD protection diodes.

⁴ Sample tested during initial release and after any redesign or process change that may affect this parameter.

⁵ On-chip reference shuts down when an external reference is applied.

⁶ The accuracy of the temperature sensor is affected by reference tolerance.

AD7416 SPECIFICATIONS

$V_{DD} = 2.7\text{ V to }5.5\text{ V}$, $GND = 0\text{ V}$, $REF_{IN} = 2.5\text{ V}$, unless otherwise noted.

Table 2.

Parameter	Min	Typ	Max	Unit	Test Conditions/Comments
TEMPERATURE SENSOR AND ADC					
Accuracy			± 2.0	$^{\circ}\text{C}$	$T_A = -25^{\circ}\text{C to }+100^{\circ}\text{C}$ ($V_{DD} = 3\text{ V minimum}$) ¹
			± 3.0	$^{\circ}\text{C}$	$T_A = -40^{\circ}\text{C to }+125^{\circ}\text{C}$ ($V_{DD} = 3\text{ V minimum}$) ¹
Resolution		10		Bits	
Temperature Conversion Time			40	μs	
Update Rate, t_R		400		μs	
OTI Delay	$1 \times t_R$		$6 \times t_R$	ms	Depends on fault queue setting
Supply Current			1.0	mA	I ² C active
		350	600	μA	I ² C inactive
		0.2	1.5	μA	Shutdown mode
T_{OTI} Default Temperature		80		$^{\circ}\text{C}$	
T_{HYST} Default Temperature		75		$^{\circ}\text{C}$	
DIGITAL INPUTS					
Input High Voltage, V_{IH}	$V_{DD} \times 0.7$		$V_{DD} + 0.5$	V	
Input Low Voltage, V_{IL}	-0.3		$V_{DD} \times 0.3$	V	
Input High Current, I_{IH}		+0.005	+1.0	μA	$V_{IN} = 5\text{ V}$
Input Low Current, I_{IL}		-0.005	-1.0	μA	$V_{IN} = 0\text{ V}$
Input Capacitance, C_{IN}		20		pF	All digital inputs
DIGITAL OUTPUTS					
Output Low Voltage, V_{OL}			0.4	V	$I_{OL} = 3\text{ mA}$
Output High Current			1	μA	$V_{OH} = 5\text{ V}$
Output Fall Time, t_f			250	ns	$C_L = 400\text{ pF}$, $I_O = 3\text{ mA}$
OS Output Low Voltage, V_{OL}			0.8	V	$I_{OUT} = 4\text{ mA}$
AC ELECTRICAL CHARACTERISTICS²					
Serial Clock Period, t_1	2.5			μs	AD7416/AD7417/AD7418 See Figure 4
Data In Setup Time to SCL High, t_2	50			ns	See Figure 4
Data Out Stable after SCL Low, t_3	0			ns	See Figure 4
SDA Low Setup Time to SCL Low (Start Condition), t_4	50			ns	See Figure 4
SDA High Hold Time after SCL High (Stop Condition), t_5	50			ns	See Figure 4
SDA and SCL Fall Time, t_6			300	ns	See Figure 4

¹ For $V_{DD} = 2.7\text{ V to }3\text{ V}$, T_A maximum = 85°C and temperature sensor measurement error = $\pm 3^{\circ}\text{C}$ maximum.

² Sample tested during initial release and after any redesign or process change that may affect this parameter.

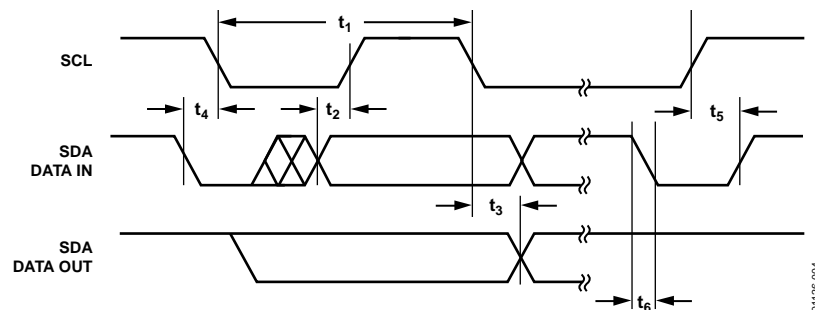

Figure 4. Diagram for Serial Bus Timing

ABSOLUTE MAXIMUM RATINGS

$T_A = 25^\circ\text{C}$, unless otherwise noted.

Table 3.

Parameter	Rating
V_{DD} to AGND	-0.3 V to +7 V
V_{DD} to DGND	-0.3 V to +7 V
Analog Input Voltage to AGND A_{IN1} to A_{IN4}	-0.3 V to $V_{DD} + 0.3$ V
Reference Input Voltage to AGND ¹	-0.3 V to $V_{DD} + 0.3$ V
Digital Input Voltage to DGND	-0.3 V to $V_{DD} + 0.3$ V
Digital Output Voltage to DGND	-0.3 V to $V_{DD} + 0.3$ V
Operating Temperature Range	
A Version	-40°C to +125°C
B Version	-40°C to +85°C
Storage Temperature Range	-65°C to +150°C
Junction Temperature	150°C
TSSOP, Power Dissipation	450 mW
θ_{JA} Thermal Impedance	120°C/W
Lead Temperature, Soldering	260°C
Vapor Phase (60 sec)	215°C
Infrared (15 sec)	220°C
16-Lead SOIC Package, Power Dissipation	450 mW
θ_{JA} Thermal Impedance	100°C/W
Lead Temperature, Soldering	
Vapor Phase (60 sec)	215°C
Infrared (15 sec)	220°C
8-Lead SOIC Package, Power Dissipation	450 mW
θ_{JA} Thermal Impedance	157°C/W
Lead Temperature, Soldering	
Vapor Phase (60 sec)	215°C
Infrared (15 sec)	220°C
MSOP Package, Power Dissipation	450 mW
θ_{JA} Thermal Impedance	206°C/W
Lead Temperature, Soldering	
Vapor Phase (60 sec)	215°C
Infrared (15 sec)	220°C

¹ If the reference input voltage is likely to exceed V_{DD} by more than 0.3 V (for example, during power-up) and the reference is capable of supplying 30 mA or more, it is recommended to use a clamping diode between the REF_{IN} pin and the V_{DD} pin. Figure 5 shows how the diode should be connected.

Stresses at or above those listed under Absolute Maximum Ratings may cause permanent damage to the product. This is a stress rating only; functional operation of the product at these or any other conditions above those indicated in the operational section of this specification is not implied. Operation beyond the maximum operating conditions for extended periods may affect product reliability.

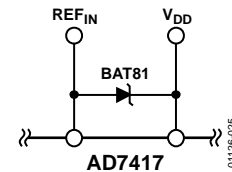

Figure 5. Diode Connection

ESD CAUTION



ESD (electrostatic discharge) sensitive device. Charged devices and circuit boards can discharge without detection. Although this product features patented or proprietary protection circuitry, damage may occur on devices subjected to high energy ESD. Therefore, proper ESD precautions should be taken to avoid performance degradation or loss of functionality.

PIN CONFIGURATIONS AND FUNCTION DESCRIPTIONS

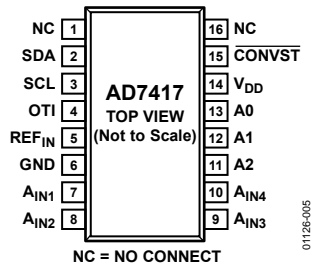

Figure 6. AD7417 Pin Configuration (SOIC/TSSOP)

Table 4. AD7417 Pin Function Descriptions

Pin No.	Mnemonic	Description
1, 16	NC	No Connection. Do not connect anything to this pin.
2	SDA	Digital I/O. Serial bus bidirectional data. Push-pull output.
3	SCL	Digital Input. Serial bus clock.
4	OTI	This pin is a logic output. The overtemperature indicator (OTI) is set if the result of a conversion on Channel 0 (temperature sensor) is greater than an 8-bit word in the T_{OTI} setpoint register. The signal is reset at the end of a serial read operation. Open-drain output.
5	REF _{IN}	Reference Input. An external 2.5 V reference can be connected to the AD7417 at this pin. To enable the on-chip reference, the REF _{IN} pin should be tied to GND. If an external reference is connected to the AD7417, the internal reference shuts down.
6	GND	Ground reference for track-and-hold, comparator and capacitor DAC, and digital circuitry.
7 to 10	A _{IN1} to A _{IN4}	Analog Input Channels. The AD7417 has four analog input channels. The input channels are single-ended with respect to GND. The input channels can convert voltage signals in the range of 0 V to VREF. A channel is selected by writing to the configuration register of the AD7417.
11	A2	Digital Input. This is the highest programmable bit of the serial bus address.
12	A1	Digital Input. This is the middle programmable bit of the serial bus address.
13	A0	Digital Input. This is the lowest programmable bit of the serial bus address.
14	V _{DD}	Positive Supply Voltage, 2.7 V to 5.5 V.
15	CONVST	Logic Input Signal. Convert start signal. The rising edge of this signal fully powers up the part. The power-up time for the part is 4 μ s. If the CONVST pulse is greater than 4 μ s, the falling edge of CONVST places the track-and-hold mode into hold mode and initiates a conversion. If the pulse is less than 4 μ s, an internal timer ensures that the track-and-hold does not go into hold, and conversion is not initiated until the power-up time has elapsed. The track-and-hold goes into track mode again at the end of conversion (see the Operating Modes section).



Figure 7. AD7416 Pin Configuration (SOIC/MSOP)

Table 5. AD7416 Pin Function Descriptions

Pin No.	Mnemonic	Description
1	SDA	Digital I/O. Serial bus bidirectional data. Push-pull output.
2	SCL	Digital Input. Serial bus clock.
3	OTI	This pin is a logic output. The OTI is set if the result of a conversion on Channel 0 (temperature sensor) is greater than an 8-bit word in the T_{OTI} setpoint register. The signal is reset at the end of a serial read operation. Open-drain output.
4	GND	Ground reference for track-and-hold, comparator and capacitor DAC, and digital circuitry.
5	A2	Digital Input. This is the highest programmable bit of the serial bus address.
6	A1	Digital Input. This is the middle programmable bit of the serial bus address.
7	A0	Digital Input. This is the lowest programmable bit of the serial bus address.
8	V_{DD}	Positive Supply Voltage, 2.7 V to 5.5 V.

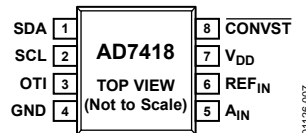

Figure 8. AD7418 Pin Configuration (SOIC/MSOP)

Table 6. AD7418 Pin Function Descriptions

Pin No.	Mnemonic	Description
1	SDA	Digital I/O. Serial bus bidirectional data. Push-pull output.
2	SCL	Digital Input. Serial bus clock.
3	OTI	This is a logic output. The OTI is set if the result of a conversion on Channel 0 (temperature sensor) is greater than an 8-bit word in the T_{OTI} setpoint register. The signal is reset at the end of a serial read operation. Open-drain output.
4	GND	Ground reference for track-and-hold, comparator and capacitor DAC, and digital circuitry.
5	A_{IN}	Analog Input Channel. The input channel is single-ended with respect to GND. The input channel can convert voltage signals in the range of 0 V to V_{REF} . The analog input channel is selected by writing to the configuration register of the AD7418 and choosing Channel 4.
6	REF_{IN}	Reference Input. An external 2.5 V reference can be connected to the AD7418 at this pin. To enable the on-chip reference, the REF_{IN} pin should be tied to GND. If an external reference is connected to the AD7418, the internal reference shuts down.
7	V_{DD}	Positive Supply Voltage, 2.7 V to 5.5 V.
8	$CONVST$	Logic Input Signal. Convert start signal. The rising edge of this signal fully powers up the part. The power-up time for the part is 4 μ s. If the $CONVST$ pulse is greater than 4 μ s, the falling edge of $CONVST$ places the track-and-hold mode into hold mode and initiates a conversion. If the pulse is less than 4 μ s, an internal timer ensures that the track-and-hold does not go into hold, and conversion is not initiated until the power-up time has elapsed. The track-and-hold goes into track mode again at the end of conversion (see the Operating Modes section).

TERMINOLOGY

Relative Accuracy

Relative accuracy or endpoint nonlinearity is the maximum deviation from a straight line passing through the endpoints of the ADC transfer function.

Differential Nonlinearity

This is the difference between the measured and the ideal 1 LSB change between any two adjacent codes in the ADC.

Offset Error

This is the deviation of the first code transition (0000...000) to (0000...001) from the ideal, that is, GND + 1 LSB.

Offset Error Match

This is the difference in offset error between any two channels.

Gain Error

This is the deviation of the last code transition (1111...110) to (1111...111) from the ideal, that is, VREF – 1 LSB, after the offset error has been adjusted out.

Gain Error Match

This is the difference in gain error between any two channels.

Track-and-Hold Acquisition Time

Track-and-hold acquisition time is the time required for the output of the track-and-hold amplifier to reach its final value, within $\pm\frac{1}{2}$ LSB, after the end of conversion (the point at which the track-and-hold returns to track mode). It also applies to situations where a change in the selected input channel takes place or where there is a step input change on the input voltage applied to the selected A_{IN} input of the AD7417 or AD7418. It means that the user must wait for the duration of the track-and-hold acquisition time after the end of conversion, or after a channel change or step input change to A_{IN} before starting another conversion, to ensure that the part operates to specification.

THEORY OF OPERATION

CIRCUIT INFORMATION

The AD7417 and AD7418 are single-channel and four-channel, 15 μ s conversion time, 10-bit ADCs with on-chip temperature sensor, reference, and serial interface logic functions on a single chip. The AD7416 has no analog input channel and is intended for temperature measurement only. The ADC section consists of a conventional successive approximation converter based around a capacitor DAC. The AD7416, AD7417, and AD7418 are capable of running on a 2.7 V to 5.5 V power supply, and the AD7417 and AD7418 accept an analog input range of 0 V to +VREF. The on-chip temperature sensor allows an accurate measurement of the ambient device temperature to be made. The working measurement range of the temperature sensor is -40°C to $+125^{\circ}\text{C}$. The parts require a 2.5 V reference that can be provided from the part's own internal reference or from an external reference source.

CONVERTER DETAILS

Conversion is initiated on the AD7417/AD7418 by pulsing the CONVST input. The conversion clock for the part is internally generated so that no external clock is required except when reading from and writing to the serial port. The on-chip track-and-hold goes from track mode to hold mode, and the conversion sequence is started on the falling edge of the CONVST signal. A conversion is also initiated in the automatic conversion mode every time a read or write operation to the AD7416/AD7417/AD7418 takes place. In this case, the internal clock oscillator (which runs the automatic conversion sequence) is restarted at the end of the read or write operation. The track-and-hold goes into hold mode approximately 3 μ s after the read or write operation is complete, and a conversion is then initiated. The result of the conversion is available either 15 μ s or 30 μ s later, depending on whether an analog input channel or the temperature sensor is selected. The track-and-hold acquisition time of the AD7417/AD7418 is 400 ns.

A temperature measurement is made by selecting the Channel 0 of the on-chip mux and carrying out a conversion on this channel. A conversion on Channel 0 takes 30 μ s to complete. Temperature measurement is explained in the Temperature Measurement section.

The on-chip reference is not available to the user, but REF_{IN} can be overdriven by an external reference source (2.5 V only).

All unused analog inputs should be tied to a voltage within the nominal analog input range to avoid noise pickup. For minimum power consumption, the unused analog inputs should be tied to GND.

TYPICAL CONNECTION DIAGRAM

Figure 9 shows a typical connection diagram for the AD7417. Using the A0, A1, and A2 pins allows the user to select from up to eight AD7417 devices on the same serial bus, if desired. An external 2.5 V reference can be connected at the REF_{IN} pin. If an

external reference is used, a 10 μ F capacitor should be connected between REF_{IN} and GND. SDA and SCL form the 2-wire I²C compatible interface. For applications where power consumption is of concern, the automatic power-down at the end of a conversion should be used to improve power performance (see the Operating Modes section.)

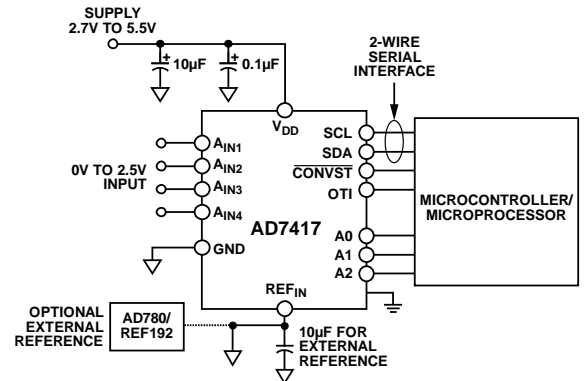

Figure 9. Typical AD7417 Connection Diagram

ANALOG INPUTS

Figure 10 shows an equivalent circuit of the analog input structure of the AD7417 and AD7418. The two diodes, D1 and D2, provide ESD protection for the analog inputs. Care must be taken to ensure that the analog input signal never exceeds the supply rails by more than 200 mV to prevent these diodes from becoming forward-biased and start conducting current into the substrate. The maximum current these diodes can conduct without causing irreversible damage to the part is 20 mA. Capacitor C2 in Figure 10 is typically about 4 pF and can primarily be attributed to pin capacitance. Resistor R1 is a lumped component made up of the on resistance of a multiplexer and a switch. This resistor is typically about 1 k Ω . Capacitor C1 is the ADC sampling capacitor and has a capacitance of 3 pF.

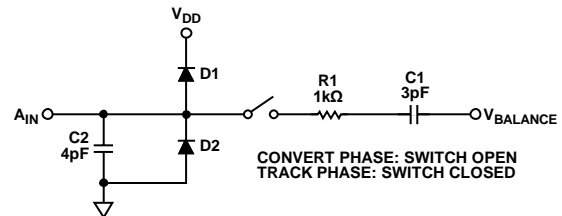

Figure 10. Equivalent Analog Input Circuit

ON-CHIP REFERENCE

The AD7417/AD7418 have an on-chip 1.2 V band gap reference that is amplified by a switched capacitor amplifier to give an output of 2.5 V. The amplifier is only powered up at the start of the conversion phase and is powered down at the end of the conversion. The on-chip reference is selected by connecting the REF_{IN} pin to analog ground, which causes SW1 (see Figure 11) to open and the reference amplifier to power up during a conversion. Therefore, the on-chip reference is not available externally.

An external 2.5 V reference can be connected to the REF_{IN} pin. This has the effect of shutting down the on-chip reference circuitry.

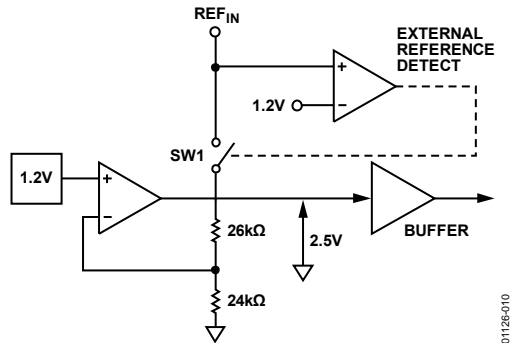

Figure 11. On-Chip Reference

TEMPERATURE MEASUREMENT

A common method of measuring temperature is to exploit the negative temperature coefficient of a diode, or the base-emitter voltage of a transistor, operated at a constant current. Unfortunately, this technique requires calibration to null out the effect of the absolute value of V_{BE}, which varies from device to device.

The technique used in the AD7416/AD7417/AD7418 is to measure the current change in V_{BE} when the device is operated at two different currents.

This is given by

$$\Delta V_{BE} = KT / q \times \ln(N)$$

where:

K is Boltzmann's constant.

q is the charge on the electron (1.6 × 10⁻¹⁹ Coulombs).

T is the absolute temperature in Kelvins.

N is the ratio of the two currents.

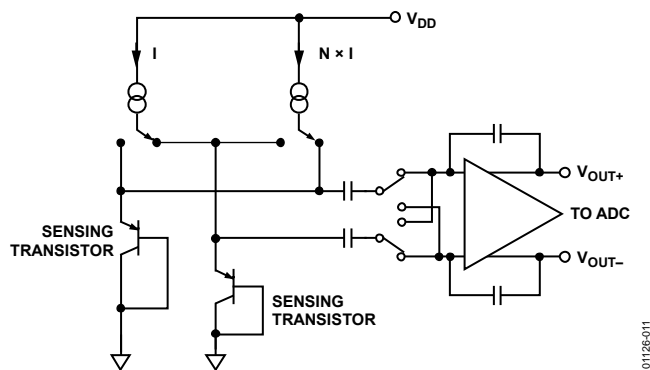

Figure 12. Temperature Measurement Technique

Figure 12 shows the method the AD7416/AD7417/AD7418 use to measure the device temperature. To measure ΔV_{BE}, the sensor (substrate transistor) is switched between operating currents of I and N × I. The resulting waveform is passed through a chopper-stabilized amplifier that performs the functions of amplification and rectification of the waveform to produce a dc voltage proportional to ΔV_{BE}. This voltage is measured by the ADC to give a temperature output in 10-bit twos complement form.

The temperature resolution of the ADC is 0.25°C, which corresponds to 1 LSB of the ADC. The ADC can theoretically measure a temperature span of 255°C; the guaranteed temperature range is -40°C to +125°C. The result of the conversion is stored in the temperature value register (0x00) as a 16-bit word. The 10 MSBs of this word store the temperature measurement (see Table 9 and Table 10).

The temperature conversion formulas using the 10 MSBs of the temperature value register are

$$\text{Positive Temperature} = \text{ADC Code}/4 \tag{1}$$

$$\text{Negative Temperature} = (\text{ADC Code} - 512)/4 \tag{2}$$

The MSB is removed from ADC Code in Equation 2.

INTERNAL REGISTER STRUCTURE

The AD7417/AD7418 have seven internal registers, as shown in Figure 13. Six of these are data registers and one is an address pointer register. The AD7416 has five internal registers (the ADC and Config2 registers are not applicable to the AD7416).

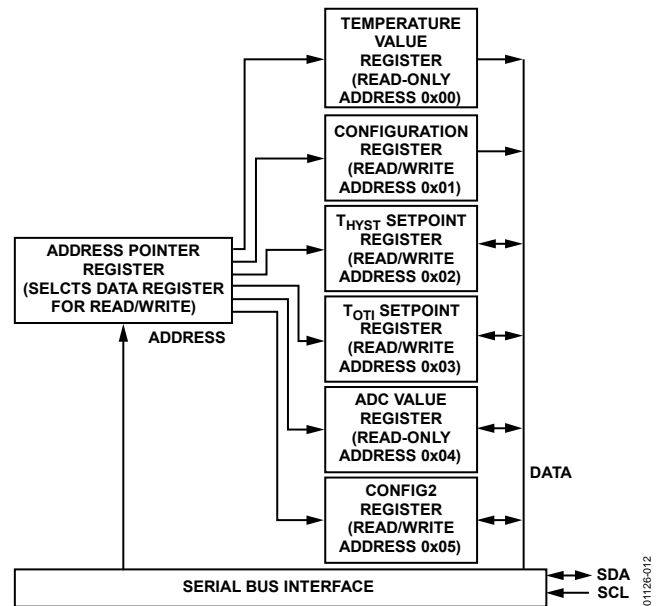

Figure 13. AD7417/AD7418 Register Structure

Address Pointer Register

The address pointer register is an 8-bit register that stores an address that points to one of the six data registers. The first data byte of every serial write operation to the AD7416/AD7417/AD7418 is the address of one of the data registers, which is stored in the address pointer register, and selects the data register to which subsequent data bytes are written. Only the three LSBs of the address pointer register are used to select a data register.

Table 7. Address Pointer Register

P7 ¹	P6 ¹	P5 ¹	P4 ¹	P3 ¹	P2	P1	P0
0	0	0	0	0	Register select		

¹ P3 to P7 must be set to 0.

Table 8. Register Addresses

P2	P1	P0	Registers
0	0	0	Temperature value
0	0	1	Configuration register
0	1	0	T _{HYST} setpoint
0	1	1	T _{OTI} setpoint
1	0	0	ADC value (AD7417/AD7418 only)
1	0	1	Config2 (AD7417/AD7418 only)

Temperature Value Register (Address 0x00)

The temperature value register is a 16-bit, read-only register whose 10 MSBs store the temperature reading from the ADC in 10-bit twos complement format. Bit D5 to Bit D0 are unused.

Table 9. Temperature Value Register

D15	D14	D13	D12	D11	D10	D9	D8	D7	D6
MSB	B8	B7	B6	B5	B4	B3	B2	B1	LSB

The temperature data format is shown in Table 10. This shows the full theoretical range of the ADC from -128°C to $+127^{\circ}\text{C}$, but in practice, the temperature measurement range is limited to the operating temperature range of the device.

Table 10. Temperature Data Format

Temperature	Digital Output
-128°C	10 0000 0000
-125°C	10 0000 1100
-100°C	10 0111 0000
-75°C	10 1101 0100
-50°C	11 0011 1000
-25°C	11 1001 1100
-10°C	11 1101 1000
-0.25°C	11 1111 1111
0°C	00 0000 0000
$+0.25^{\circ}\text{C}$	00 0000 0001
$+10^{\circ}\text{C}$	00 0010 1000
$+25^{\circ}\text{C}$	00 0110 0100
$+50^{\circ}\text{C}$	00 1100 1000
$+75^{\circ}\text{C}$	01 0010 1100
$+100^{\circ}\text{C}$	01 1001 0000
$+125^{\circ}\text{C}$	01 1111 0100
$+127^{\circ}\text{C}$	01 1111 1100

Configuration Register (Address 0x01)

The configuration register is an 8-bit, read/write register that is used to set the operating modes of the AD7416/AD7417/AD7418. Bit D7 to Bit D5 control the channel selection as outlined in Table 12. Bits[D7:D5] should always be set to 000 for the AD7416. Bit D4 and Bit D3 are used to set the length of the fault queue. D2 sets the sense of the OTI output. D1 selects the comparator or interrupt mode of operation, and D0 = 1 selects the shutdown mode (default: D0 = 0).

Table 11. Configuration Register

D7	D6	D5	D4	D3	D2	D1	D0
Channel selection			Fault queue		OTI polarity	Cmp/Int	Shutdown

The AD7416 contains a temperature-only channel; the AD7417 has four analog input channels and a temperature channel; and the AD7418 has two channels, a temperature channel, and an analog input channel. The temperature channel address for all parts is the same, Channel 0. The address for the analog input channel on the AD7418 is Channel 4. Table 12 outlines the channel selection on the parts, and Table 13 shows the fault queue settings. D1 and D2 are explained in the OTI Output section.

Table 12. Channel Selection

D7	D6	D5	Channel Selection
0	0	0	Temperature sensor (all parts), Channel 0
0	0	1	A _{IN1} (AD7417 only), Channel 1
0	1	0	A _{IN2} (AD7417 only), Channel 2
0	1	1	A _{IN3} (AD7417 only), Channel 3
1	0	0	A _{IN4} (AD7417) and A _{IN} (AD7418), Channel 4

Table 13. Fault Queue Settings

D4	D3	Number of Faults
0	0	1 (power-up default)
0	1	2
1	0	4
1	1	6

T_{HYST} Setpoint Register (Address 0x02)

The T_{HYST} setpoint register is a 16-bit, read/write register whose nine MSBs store the T_{HYST} setpoint in twos complement format equivalent to the nine MSBs of the temperature value register. Bit D6 to Bit D0 are unused.

T_{OTI} Setpoint Register (Address 0x03)

The T_{OTI} setpoint register is a 16-bit, read/write register whose nine MSBs store the T_{OTI} setpoint in twos complement format equivalent to the nine MSBs of the temperature value register. Bit 6 to Bit 0 are unused.

Table 14. T_{HYST} Setpoint and T_{OTI} Setpoint Registers

D15	D14	D13	D12	D11	D10	D9	D8	D7
MSB	B7	B6	B5	B4	B3	B2	B1	LSB

ADC Value Register (Address 0x04)

The ADC value register is a 16-bit, read-only register whose 10 MSBs store the value produced by the ADC in binary format. Bit D5 to Bit D0 are unused. Table 15 shows the ADC value register with 10 MSBs containing the ADC conversion request.

Table 15. ADC Value Register

D15	D14	D13	D12	D11	D10	D9	D8	D7	D6
MSB	B8	B7	B6	B5	B4	B3	B2	B1	LSB

ADC Transfer Function

The designed code transitions occur at successive integer LSB values (that is, 1 LSB, 2 LSB, and so on). The LSB size = VREF/1024. The ideal transfer function characteristic for the AD7417 and AD7418 ADC is shown in Figure 14.

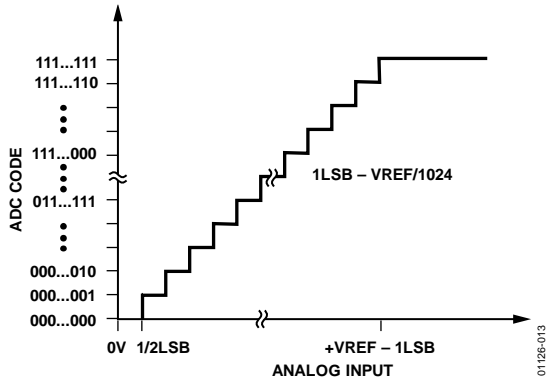

Figure 14. Ideal Transfer Function Characteristic for the AD7417/AD7418

Config2 Register (Address 0x05)

A second configuration register is included in the AD7417/AD7418 for the functionality of the CONVST pin. It is an 8-bit register with Bit D5 to Bit D0 being left at 0. Bit D7 determines whether the AD7417/AD7418 should be operated in its default mode ($D7 = 0$), performing conversions every 355 μ s or in its CONVST pin mode ($D7 = 1$), where conversions start only when the CONVST pin is used. Bit 6 contains the Test 1 bit. When this bit is 0, the I²C filters are enabled (default). Setting this bit to 1 disables the filters.

Table 16. Config2 Register

D7	D6	D5	D4	D3	D2	D1	D0
Conversion mode	Test 1	0	0	0	0	0	0

SERIAL BUS INTERFACE

Control of the AD7416/AD7417/AD7418 is carried out via the I²C compatible serial bus. The AD7416/AD7417/AD7418 are connected to this bus as a slave device, under the control of a master device, for example, the processor.

Serial Bus Address

As with all I²C compatible devices, the AD7416/AD7417/AD7418 have a 7-bit serial address. The four MSBs of this address for the AD7416 are set to 1001; the AD7417 are set to 0101, and the three LSBs can be set by the user by connecting the A2 to A0 pins to either V_{DD} or GND. By giving them different addresses, up to eight AD7416/AD7417 devices can be connected to a single serial bus, or the addresses can be set to avoid conflicts with other devices on the bus. The four MSBs of this address for the AD7418 are set to 0101, and the three LSBs are all set to 0.

If a serial communication occurs during a conversion operation, the conversion stops and restarts after the communication.

The serial bus protocol operates as follows:

1. The master initiates data transfer by establishing a start condition, defined as a high-to-low transition on the serial data line, SDA, while the serial clock line, SCL, remains high. This indicates that an address/data stream follows. All slave peripherals connected to the serial bus respond to the 7-bit address (MSB first) plus an R/W bit, which determines the

direction of the data transfer, that is, whether data is written to or read from the slave device.

The peripheral whose address corresponds to the transmitted address responds by pulling the data line low during the low period before the ninth clock pulse, known as the acknowledge bit. All other devices on the bus now remain idle while the selected device waits for data to be read from or written to it. If the R/W bit is a 0, then the master writes to the slave device. If the R/W bit is a 1, then the master reads from the slave device.

2. Data is sent over the serial bus in sequences of nine clock pulses, eight bits of data followed by an acknowledge bit from the receiver of data. Transitions on the data line must occur during the low period of the clock signal and remain stable during the high period, because a low-to-high transition when the clock is high may be interpreted as a stop signal.
3. When all data bytes have been read or written, stop conditions are established. In write mode, the master pulls the data line high during the 10th clock pulse to assert a stop condition. In read mode, the master device pulls the data line high during the low period before the ninth clock pulse. This is known as no acknowledge. The master then takes the data line low during the low period before the 10th clock pulse, then high during the 10th clock pulse to assert a stop condition.

Any number of bytes of data can be transferred over the serial bus in one operation, but it is not possible to mix read and write in one operation because the type of operation is determined at the beginning and cannot subsequently be changed without starting a new operation.

Writing to the AD7416/AD7417/AD7418

Depending on the register being written to, there are three different writes for the AD7416/AD7417/AD7418.

- Writing to the address pointer register for a subsequent read. To read data from a particular register, the address pointer register must contain the address of that register. If it does not, the correct address must be written to the address pointer register by performing a single-byte write operation, as shown in Figure 15. The write operation consists of the serial bus address followed by the address pointer byte. No data is written to any of the data registers.
- Writing a single byte of data to the configuration register, the Config2 register, or to the T_{OTI} setpoint or T_{HYST} setpoint registers. The configuration register is an 8-bit register, so only one byte of data can be written to it. If only 8-bit temperature comparisons are required, the temperature LSB can be ignored in T_{OTI} and T_{HYST}, and only eight bits need to be written to the T_{OTI} setpoint and T_{HYST} setpoint registers. Writing a single byte of data to one of these registers consists of the serial bus address, the data register address written to the address pointer register, followed by the data byte

written to the selected data register. This is illustrated in Figure 16.

- Writing two bytes of data to the T_{OTI} setpoint or T_{HYST} setpoint register.

If 9-bit resolution is required for the temperature setpoints, two bytes of data must be written to the T_{OTI} setpoint and

T_{HYST} setpoint registers. This consists of the serial bus address, the register address written to the address pointer register, followed by two data bytes written to the selected data register. This is illustrated in Figure 17.

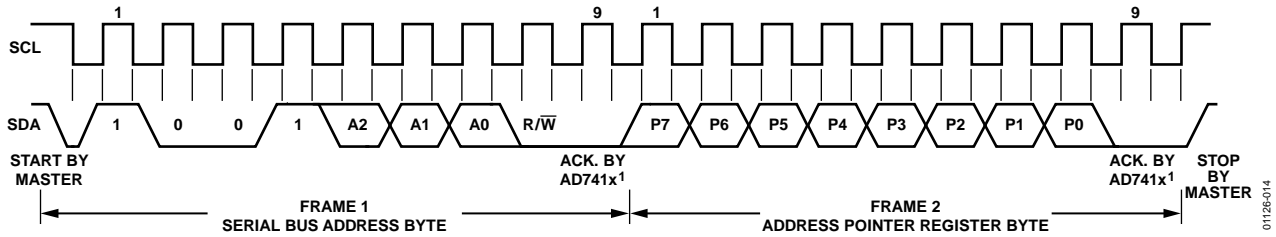

¹AD741x = AD7416/AD7417/AD7418.

Figure 15. Writing to the Address Pointer Register to Select a Data Register for a Subsequent Read Operation

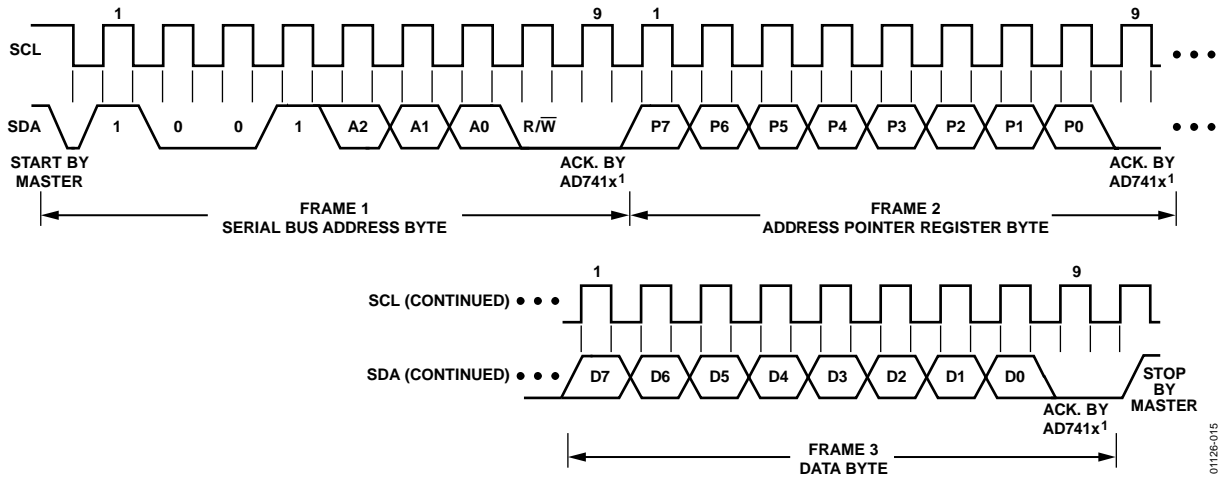

¹AD741x = AD7416/AD7417/AD7418.

Figure 16. Writing to the Address Pointer Register Followed by a Single Byte of Data to the Selected Data Register

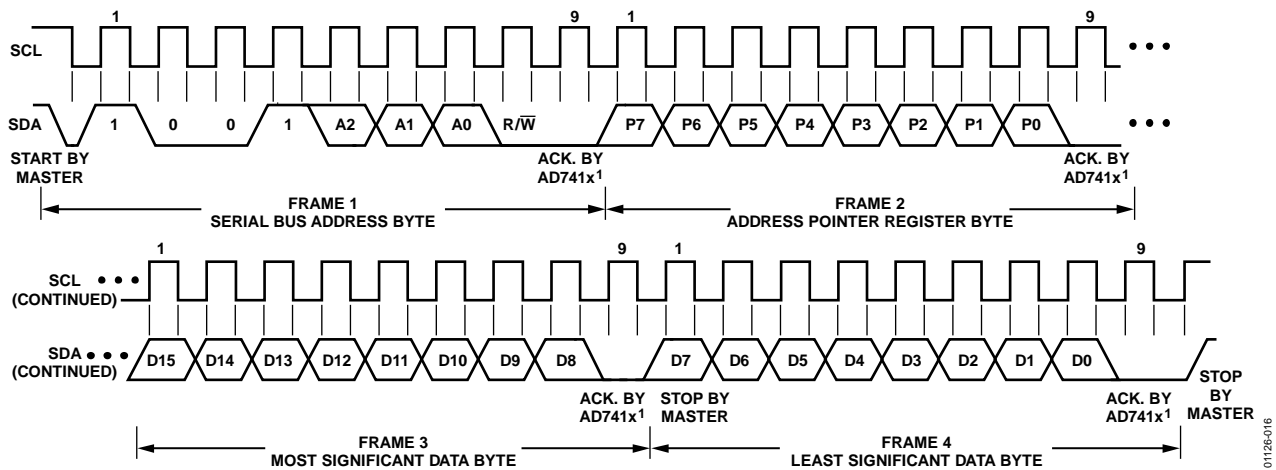

¹AD741x = AD7416/AD7417/AD7418.

Figure 17. Writing to the Address Pointer Register Followed by Two Bytes of Data to the T_{OTI} Setpoint or T_{HYST} Setpoint Register

Reading Data From the AD7416/AD7417/AD7418

Reading data from the AD7416/AD7417/AD7418 is a single-byte or 2-byte operation. Reading back the contents of the configuration register is a single-byte read operation, as shown in Figure 18, with the register address previously having been set by a single-byte write operation to the address pointer register.

Reading data from the temperature value register, the T_{OT1} setpoint or T_{HYST} setpoint register is a 2-byte operation, as shown in Figure 19. It is also possible to read the most significant bit of a 9-bit or 10-bit register in this manner.

Note that when reading back from the AD7416/AD7417/AD7418, no more than three bytes of data must be read back. A stop command must be inserted at the end of the read communication. If a stop command is not inserted by the master and the AD7416/AD7417/AD7418 receive more SCL cycles than the maximum needed for three bytes of data, then the I²C interface on the AD7416/AD7417/AD7418 pulls the SDA line low and prevents it from going high again. To recover the AD7416/AD7417/AD7418 interface, the part must be powered off and on again. Reference the AN-686 Application Note, *Implementing an I²C® Reset* at www.analog.com for more information on I²C interfaces.

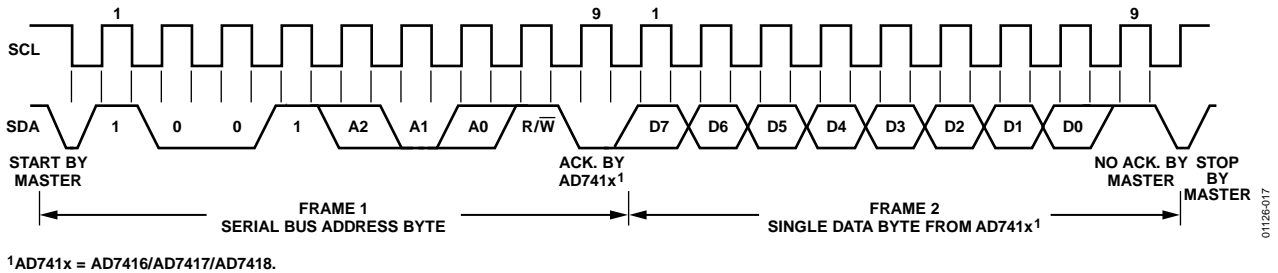

Figure 18. Reading a Single Byte of Data from the Configuration Register

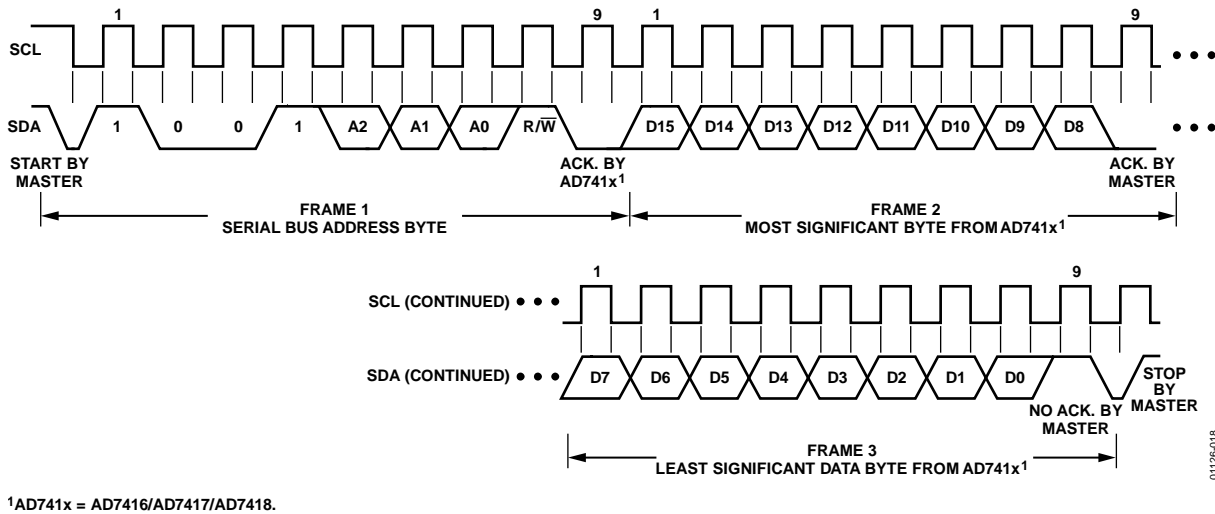

Figure 19. Reading Two Bytes of Data from the T_{OT1} Setpoint or T_{HYST} Setpoint Register

OTI OUTPUT

The OTI output has two operating modes that are selected by Bit D1 of the configuration register. In the comparator mode, ($D1 = 0$), the OTI output becomes active when the temperature exceeds T_{OTI} and remains active until the temperature falls below T_{HYST} . This mode allows the AD7416/AD7417/AD7418 to be used as a thermostat, for example, to control the operation of a cooling fan.

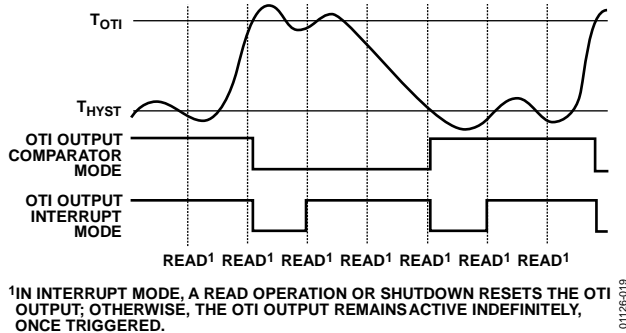

Figure 20. Operation of OTI Output (Shown Active Low)

The open-drain configuration of OTI allows the OTI outputs of several AD7416/AD7417/AD7418 devices to be wire-AND'ed together when in active low mode.

The OTI output is used to indicate that an out-of-limit temperature excursion has occurred. OTI is an open-drain output that can be programmed to be active low by setting Bit D2 of the configuration register to 0 or active high by setting Bit D2 of the configuration register to 1.

In the interrupt mode ($D1 = 1$), the OTI output becomes active when the temperature exceeds T_{OTI} and remains active even if the temperature falls below T_{HYST} , until it is reset by a read operation. Once OTI becomes active by the temperature exceeding T_{OTI} , and resets, it remains inactive even if the temperature remains, or subsequently rises again, above T_{OTI} . It does not become active again until the temperature falls below T_{HYST} . It then remains active until reset by a read operation. Once OTI becomes active by the temperature falling below T_{HYST} and then resets, it remains inactive even if the temperature remains, or subsequently falls again, below T_{HYST} .

OTI is also reset when the AD7416/AD7417/AD7418 are placed in shutdown mode by setting Bit D0 of the configuration register to 1.

The OTI output requires an external pull-up resistor. This can be connected to a voltage different from V_{DD} (for example, to allow interfacing between 5 V and 3.3 V systems) provided that the maximum voltage rating of the OTI output is not exceeded.

The value of the pull-up resistor depends on the application but should be as large as possible to avoid excessive sink currents at the OTI output, which can heat the chip and affect the temperature reading. The maximum value of the pull-up resistor that meets the output high current specification of the OTI output is 30 k Ω , but higher values can be used if a lower output current is required. For most applications, a value of 10 k Ω is suitable.

FAULT QUEUE

To avoid false triggering of the AD7416/AD7417/AD7418 in noisy environments, a fault queue counter is provided that can be programmed by Bit D3 and Bit D4 of the configuration register (see Table 11) to count 1, 2, 4, or 6 fault events before OTI becomes active. To trigger OTI, the faults must occur consecutively. For example, if the fault queue is set to 4, then four consecutive temperature measurements greater than T_{OTI} (or less than T_{HYST}) must occur. Any reading that breaks the sequence resets the fault queue counter, so if there are three readings greater than T_{OTI} followed by a reading less than T_{OTI} , the fault queue counter is reset without triggering OTI.

POWER-ON DEFAULTS

The AD7416/AD7417/AD7418 always power up with the following defaults:

- Address pointer pointing to temperature value register comparator mode
- $T_{OTI} = 80^{\circ}\text{C}$
- $T_{HYST} = 75^{\circ}\text{C}$
- OTI active low
- Fault queue = 1

These default settings allow the AD7416/AD7417/AD7418 to be used as a standalone thermostat without any connection to a serial bus.

OPERATING MODES

The AD7416/AD7417/AD7418 have two possible modes of operation depending on the value of D0 in the configuration register.

Mode 1

Normal operation of the AD7416/AD7417/AD7418 occurs when $D0 = 0$. In this active mode, a conversion takes place every 400 μs . After the conversion has taken place, the part partially powers down, consuming typically 350 μA of the current until the next conversion occurs.

Two situations can arise in this mode on the request of a temperature read. If a read occurs during a conversion, the conversion aborts and a new one starts on the stop/repeat start condition. The temperature value that is read is that of the previous completed conversion. The next conversion typically occurs 400 μs after the new conversion has begun.

If a read is called between conversions, a conversion is initiated on the stop/repeat start condition. After this conversion, the part returns to performing a conversion every 400 μs .

With $V_{DD} = 3\text{ V}$ for each 400 μs cycle, the AD7416/AD7417/AD7418 spend 40 μs (or 10% of the time) in conversion mode. The part spends 360 μs (or 90% of time) in partial power-down mode. Thus, the average power dissipated by the AD7416/AD7417/AD7418 is

$$3\text{ mW} \times 0.1 + 1\text{ mW} \times 0.9 = 1.2\text{ mW}$$

Mode 2

For applications where temperature measurements are required at a slower rate, for example, every second, power consumption of the part can be reduced by writing to the part to go to a full power-down between reads. The current consumption in full power-down is typically 0.2 μA and full power-down is initiated when $D0 = 1$ in the configuration register. When a measurement is required, a write operation can be performed to power up the part. The part then performs a conversion and is returned to power-down. The temperature value can be read in full power-down because the I²C bus is continuously active.

The power dissipation in this mode depends on the rate at which reads take place. Taking the requirements for a temperature measurement every 100 ms as an example, the optimum power dissipation is achieved by placing the part in full power-down, waking it up every 100 ms, letting it operate for 400 μs and putting it into full power-down again. In this case, the average power consumption is calculated as follows. The part spends 40 μs (or 0.04% of time) converting with 3 mW dissipation and a 99.96 ms (99.96% of time) in full shutdown with 60 nW dissipation.

Thus, the average power dissipation is

$$3 \text{ mW} \times 0.004 + 60 \text{ nW} \times 0.9996 = 1.2 \text{ } \mu\text{W}$$

The fastest throughput rate at which the AD7416/AD7417/AD7418 can be operated is 2.5 kHz (that is, a read every 400 μs conversion period). Because T_{OTI} and T_{HYST} are 2-byte reads, the read time with the I²C operating at 100 kbps would be 270 μs . If temperature reads are called too often, reads will overlap with conversions, aborting them continuously, which results in invalid readings.

CONVST START MODE

The AD7417/AD7418 have an extra mode, set by writing to the MSB of the Config2 register.

CONVST Pin Mode

Conversions are initiated only by using the $\overline{\text{CONVST}}$ pin. In this method of operation, $\overline{\text{CONVST}}$ is normally low.

The rising edge of $\overline{\text{CONVST}}$ starts the power-up time. This power-up time is 4 μs . If the $\overline{\text{CONVST}}$ high time is longer than 4 μs , a conversion is initiated on the falling edge of $\overline{\text{CONVST}}$ and the track-and-hold also enters its hold mode at this time. If the $\overline{\text{CONVST}}$ high time is less than 4 μs , an internal timer, initiated by the rising edge of $\overline{\text{CONVST}}$, holds off the track-and-hold and the initiation of conversion until the timer times out (4 μs after the rising edge of $\overline{\text{CONVST}}$, which corresponds with the power-up time). The $\overline{\text{CONVST}}$ input remains low at the end of conversion, thus causing the part to enter its power-down mode. In this method of operation, $\overline{\text{CONVST}}$ is normally low with a high going pulse controlling the power-up, and the conversion starts.

The $\overline{\text{CONVST}}$ pin should not be pulsed when reading from or writing to the port.

Figure 21 shows the recommended minimum times for the $\overline{\text{CONVST}}$ pulse when the temperature channel is selected.

Figure 22 shows the minimum times an analog input channel is selected.

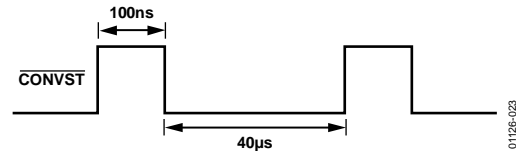

Figure 21. $\overline{\text{CONVST}}$ When Temperature Channel Selected

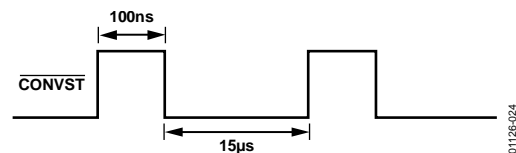

Figure 22. $\overline{\text{CONVST}}$ When V_{IN} Channel Selected

APPLICATIONS INFORMATION

SUPPLY DECOUPLING

The AD7416/AD7417/AD7418 should be decoupled with a 0.1 μF ceramic capacitor between V_{DD} and GND. This is particularly important if the part is mounted remote from the power supply.

POWER-ON RESET

To ensure proper power-on reset, make sure that the supply voltage on the V_{DD} pin is at 0 V. Refer to the AN-588 Application Note, *AD7416/AD7417/AD7418 Power-On Reset Circuit* at www.analog.com for more information. A failed power-on reset can prevent the default values from being loaded into the AD7416/AD7417/AD7418 registers. If the correct values are not loaded into the registers, then the device cannot start operating. The output from the temperature value and ADC value registers will be a constant value.

To restart the device operation, the registers have to be loaded with their default values via the I²C bus. Therefore, in the event of an inadequate power-on reset and for all three devices, the following registers should be loaded with their default values:

- Configuration register—default value = 0x00
- Config2 register—default value = 0x00
- T_{HYST} setpoint register—default value = 0x4B00
- T_{OTI} setpoint register—default value = 0x5500

MOUNTING THE AD7416/AD7417/AD7418

The AD7416/AD7417/AD7418 can be used for surface or air temperature sensing applications. If the device is cemented to a surface with thermally conductive adhesive, the die temperature is within about 0.2°C of the surface temperature, due to the low power consumption of the device. Take care to insulate the back and leads of the device from the air if the ambient air temperature is different from the surface temperature being measured.

The GND pin provides the best thermal path to the die, so the temperature of the die is close to that of the printed circuit ground track. Take care to ensure that this is in close thermal contact with the surface being measured.

As with any IC, the AD7416/AD7417/AD7418 and its associated wiring and circuits must be kept free from moisture to prevent leakage and corrosion, particularly in cold conditions where condensation is more likely to occur. Water resistant varnishes and conformal coatings can be used for protection. The small size of the AD7416 package allows it to be mounted inside sealed metal probes that provide a safe environment for the device.

FAN CONTROLLER

Figure 23 shows a simple fan controller that switches on a cooling fan when the temperature exceeds 80°C and switches it off again when the temperature falls below 75°C. The AD7416 can be used as a standalone device in this application or with a serial bus interface if different trip temperatures are required. If the AD7416 is used with a bus interface, the sense of OTI can be set to active high, Q1 and R1 can be omitted, and OTI can be connected directly to the gate of Q2, with R2 as the pull-up resistor.

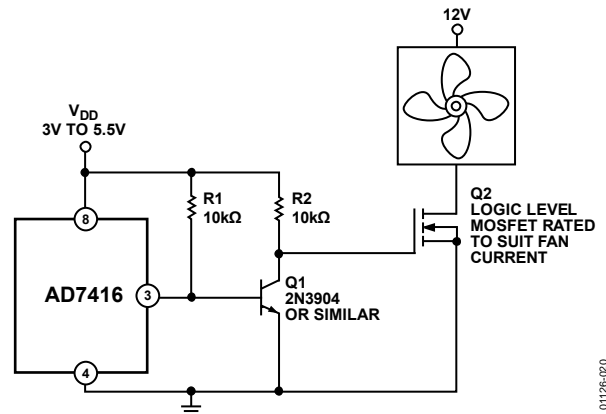

Figure 23. AD7416 Used as a Fan Controller

THERMOSTAT

Figure 24 shows the AD7416 used as a thermostat. The heater switches on when the temperature falls below T_{HYST} and switches off again when the temperature rises above T_{OTI} . For this application and for comparator mode, program the OTI output active low.

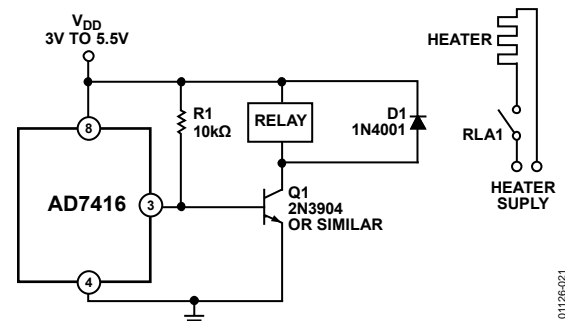

Figure 24. AD7416 Used as a Thermostat

SYSTEM WITH MULTIPLE AD7416 DEVICES

The three LSBs of the AD7416 serial address can be set by the user, allowing eight different addresses from 1001000 to 1001111. Figure 25 shows a system in which eight AD7416 devices are connected to a single serial bus, with their OTI outputs wire-ANDed together to form a common interrupt

line. This arrangement means that each device must be read to determine which one has generated the interrupt, and if a unique interrupt is required for each device, the OTI outputs can be connected separately to the I/O chip.

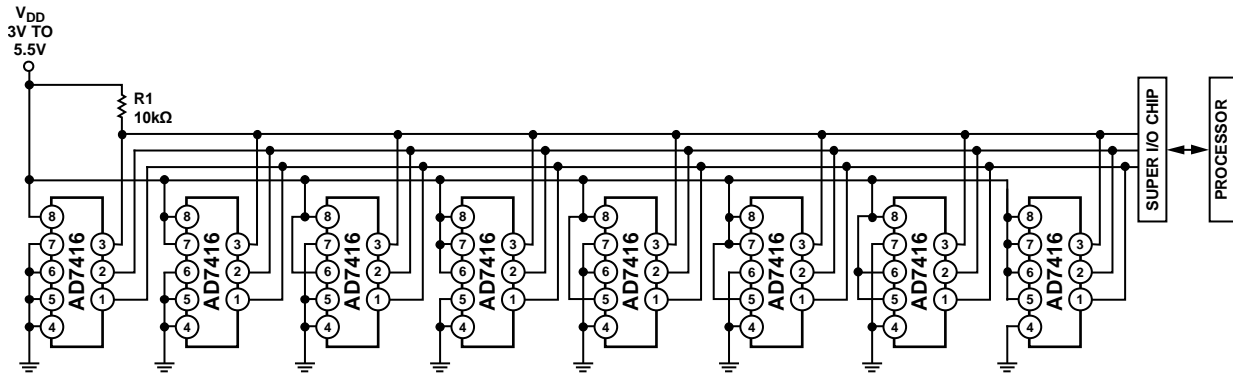
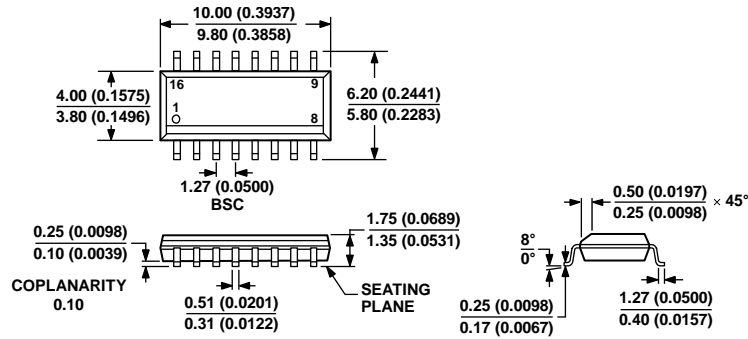

Figure 25. Multiple Connection of AD7416 Devices to a Single Serial Bus

01126-022

OUTLINE DIMENSIONS



COMPLIANT TO JEDEC STANDARDS MS-012-AC
 CONTROLLING DIMENSIONS ARE IN MILLIMETERS; INCH DIMENSIONS
 (IN PARENTHESES) ARE ROUNDED-OFF MILLIMETER EQUIVALENTS FOR
 REFERENCE ONLY AND ARE NOT APPROPRIATE FOR USE IN DESIGN.

Figure 26. 16-Lead Standard Small Outline Package [SOIC_N]
 Narrow Body
 (R-16)
 Dimensions shown in millimeters and (inches)

060606-A

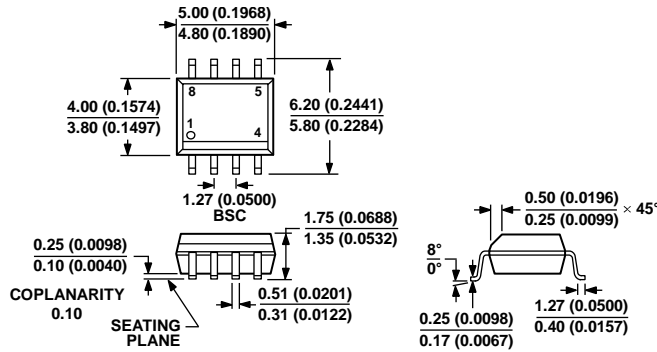

COMPLIANT TO JEDEC STANDARDS MS-012-AA
 CONTROLLING DIMENSIONS ARE IN MILLIMETERS; INCH DIMENSIONS
 (IN PARENTHESES) ARE ROUNDED-OFF MILLIMETER EQUIVALENTS FOR
 REFERENCE ONLY AND ARE NOT APPROPRIATE FOR USE IN DESIGN.

Figure 27. 8-Lead Standard Small Outline Package [SOIC_N]
 Narrow Body
 (R-8)
 Dimensions shown in millimeters and (inches)

012407-A

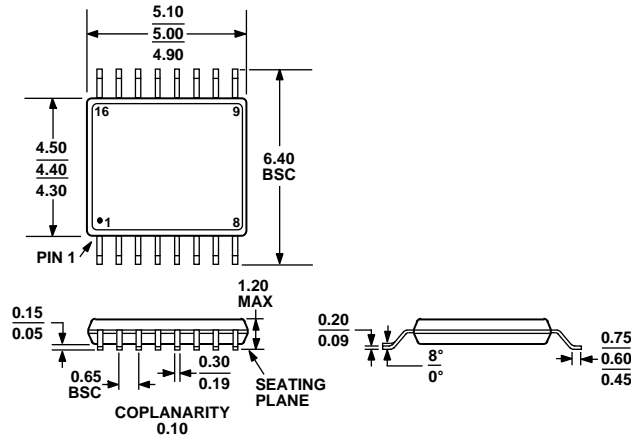

COMPLIANT TO JEDEC STANDARDS MO-153-AB

Figure 28. 16-Lead Thin Shrink Small Outline Package [TSSOP] (RU-16)

Dimensions shown in millimeters

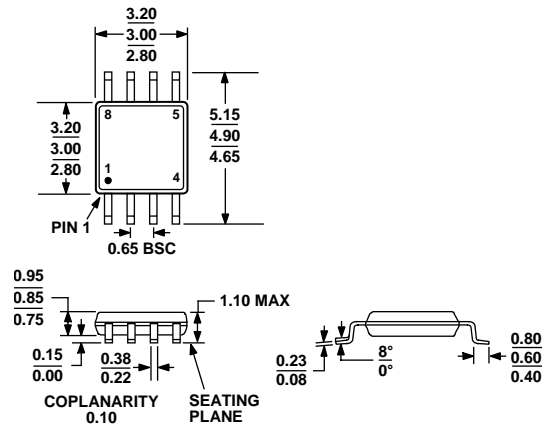

COMPLIANT TO JEDEC STANDARDS MO-187-AA

Figure 29. 8-Lead Mini Small Outline Package [MSOP] (RM-8)

Dimensions shown in millimeters

ORDERING GUIDE

Model ¹	Temperature Range	Temperature Error	Package Description	Marking Code ²	Package Option
AD7416ARZ	-40°C to +125°C	±2°C	8-Lead Standard Small Outline Package [SOIC_N]		R-8
AD7416ARZ-REEL	-40°C to +125°C	±2°C	8-Lead Standard Small Outline Package [SOIC_N]		R-8
AD7416ARZ-REEL7	-40°C to +125°C	±2°C	8-Lead Standard Small Outline Package [SOIC_N]		R-8
AD7416ARM	-40°C to +125°C	±2°C	8-Lead Mini Small Outline Package [MSOP]	C6A	RM-8
AD7416ARM-REEL7	-40°C to +125°C	±2°C	8-Lead Mini Small Outline Package [MSOP]	C6A	RM-8
AD7416ARMZ	-40°C to +125°C	±2°C	8-Lead Mini Small Outline Package [MSOP]	C6A#	RM-8
AD7416ARMZ-REEL	-40°C to +125°C	±2°C	8-Lead Mini Small Outline Package [MSOP]	C6A#	RM-8
AD7416ARMZ-REEL7	-40°C to +125°C	±2°C	8-Lead Mini Small Outline Package [MSOP]	C6A#	RM-8

Model ¹	Temperature Range	Temperature Error	Package Description	Marking Code ²	Package Option
AD7417AR	-40°C to +125°C	±2°C	16-Lead Standard Small Outline Package [SOIC_N]		R-16
AD7417AR-REEL	-40°C to +125°C	±2°C	16-Lead Standard Small Outline Package [SOIC_N]		R-16
AD7417ARZ	-40°C to +125°C	±2°C	16-Lead Standard Small Outline Package [SOIC_N]		R-16
AD7417ARZ-REEL	-40°C to +125°C	±2°C	16-Lead Standard Small Outline Package [SOIC_N]		R-16
AD7417ARZ-REEL7	-40°C to +125°C	±2°C	16-Lead Standard Small Outline Package [SOIC_N]		R-16
AD7417ARU	-40°C to +125°C	±2°C	16-Lead Thin Shrink Small Outline Package [TSSOP]		RU-16
AD7417ARU-REEL	-40°C to +125°C	±2°C	16-Lead Thin Shrink Small Outline Package [TSSOP]		RU-16
AD7417ARU-REEL7	-40°C to +125°C	±2°C	16-Lead Thin Shrink Small Outline Package [TSSOP]		RU-16
AD7417ARUZ	-40°C to +125°C	±2°C	16-Lead Thin Shrink Small Outline Package [TSSOP]		RU-16
AD7417ARUZ-REEL	-40°C to +125°C	±2°C	16-Lead Thin Shrink Small Outline Package [TSSOP]		RU-16
AD7417ARUZ-REEL7	-40°C to +125°C	±2°C	16-Lead Thin Shrink Small Outline Package [TSSOP]		RU-16
AD7417BR	-40°C to +85°C	±1°C	16-Lead Standard Small Outline Package [SOIC_N]		R-16
AD7417BR-REEL7	-40°C to +85°C	±1°C	16-Lead Standard Small Outline Package [SOIC_N]		R-16
AD7417BRZ	-40°C to +85°C	±1°C	16-Lead Standard Small Outline Package [SOIC_N]		R-16
AD7417BRZ-REEL	-40°C to +85°C	±1°C	16-Lead Standard Small Outline Package [SOIC_N]		R-16
AD7417BRZ-REEL7	-40°C to +85°C	±1°C	16-Lead Standard Small Outline Package [SOIC_N]		R-16
AD7418ACHIPS			Die		
AD7418ARZ	-40°C to +125°C	±2°C	8-Lead Standard Small Outline Package [SOIC_N]		R-8
AD7418ARZ-REEL	-40°C to +125°C	±2°C	8-Lead Standard Small Outline Package [SOIC_N]		R-8
AD7418ARZ-REEL7	-40°C to +125°C	±2°C	8-Lead Standard Small Outline Package [SOIC_N]		R-8
AD7418ARM	-40°C to +125°C	±2°C	8-Lead Mini Small Outline Package [MSOP]	C7A	RM-8
AD7418ARMZ	-40°C to +125°C	±2°C	8-Lead Mini Small Outline Package [MSOP]	TOG	RM-8
AD7418ARMZ-REEL7	-40°C to +125°C	±2°C	8-Lead Mini Small Outline Package [MSOP]	TOG	RM-8
EVAL-AD7416/7/8EBZ			Evaluation Board		

¹ Z = RoHS Compliant Part.

² # denotes RoHS compliant product may be top or bottom marked.

I²C refers to a communications protocol originally developed by Philips Semiconductors (Now NXP Semiconductors).